

SupplyHouse 3/8/2026
 shipping is \$807
 including upstairs tubing

Goods & Services Supplied

Tubing

Part Number	Description	Quantity	Unit	Price
A1220313	5/16" Wirsbo hePEX, 1,000 ft. coil	2	Ea	\$1,736.00
A1140313	5/16" Wirsbo hePEX, 100 ft. coil	1	Ea	\$0.00

Subtotal: \$2,253.00

see upstairs, there is 100'
 left on the 1000' roll

Fittings

Part Number	Description	Quantity	Unit	Price
A2660701	TruFLOW Jr. Assembly with Isolation and Balancing Valves, 7-loop	1	Ea	on site
A2660601	TruFLOW Jr. Assembly with Isolation and Balancing Valves, 6-loop	1	Ea	on site
A4020313	5/16" QS-style Compression Fitting Assembly, R20 thread	26	Ea	on site
A2123210	Threaded Brass Manifold Bushing, R32 Male x 1" Female NPT	4	Ea	on site

Subtotal: \$0

Controls

Part Number	Description	Quantity	Unit	Price
A3100101	Heat-only Thermostat with Touchscreen	1	Ea	on site
A3031003	Three-zone Control Module for Two and Four-wire Operation	2	Ea
A3010100	Single-zone Pump Relay	1	Ea	\$154.00

Subtotal: \$154.00

TACO SR501

Quik Trak

Part Number	Description	Quantity	Unit	Price
A5060701	Quik Trak 7" x 48" Panels	453	Ea	on site
A5060702	Quik Trak 7" x 48" Return Panels	49	Ea	on site
E6050010	Quik Trak Sealant, 10.3 fluid oz. (300 ml)	20	Ea	lowes
E6051250	Quik Trak Screws (1 1/4") (2500/pkg)	3	Pkg	lowes

Subtotal: \$100.00

Accessories

Part Number	Description	Quantity	Unit	Price
A5150375	3/8" Plastic Bend Support	26	Ea	on site
E6061000	Tube Uncoiler	1	Ea	on site
E6081128	Tube Cutter (plastic) for up to 1" PEX	1	Ea	lowes

Subtotal: \$20.00

Total Quote Price:

\$3,064.00

re: \$807 freight: originally bought everything from Ferguson in Anchorage. They started charging freight on non-stock parts. Worth shopping the diff with SupplyHouse, or finding a freight forwarder from Seattle. Note that SupplyHouse tends to break up shipments so the forwarder would need to be able to handle that. They ship UPS Ground free to lower 48. There's a 1000' spool box downstairs. Weighs 36lbs.

IN NO EVENT WILL
 THEORY FOR ANY
 BUSINESS PROFITS
 DAMAGES. AVENIR
 LIMITED TO NO GR

LEGAL OR EQUITABLE
 BES FOR LOSS OF
 THE POSSIBILITY OF SUCH
 OF THE ACTION, SHALL BE

Project Information

Project #: 611 W 11th Downstairs

Notes:

Name:

Location:

Circuit Stock Summary

Part Number	Description	Quantity
A1220313	5/16" Wirsbo hePEX, 1,000 ft. coil	2
A1140313	5/16" Wirsbo hePEX, 100 ft. coil	1

Coil Summary

Coil	Part Number	Coil Length (ft)	Tube Type	Length Used (ft)
Coil 1	A1220313	1,000	hePEX 5/16"	981
Coil 2	A1140313	100	hePEX 5/16"	96
Coil 3	A1220313	1,000	hePEX 5/16"	968

Circuits Cut Schedule

Main Floor

Circuit	Length (ft)	Location	Coil	Coil Length (ft)
A-1	120	Main Floor;Manifold 1;Primary Bath	Coil 3	1,000
A-2	216	Main Floor;Manifold 2;Living Room	Coil 1	1,000
A-3	152	Main Floor;Manifold 1;Primary Bedroom	Coil 1	1,000
A-4	118	Main Floor;Manifold 1;Guest Bedroom	Coil 1	1,000
A-5	152	Main Floor;Manifold 1;Guest Bedroom	Coil 1	1,000
A-6	96	Main Floor;Manifold 1;Guest Bath	Coil 2	100
A-7	105	Main Floor;Manifold 2;Kitchen	Coil 3	1,000
A-8	216	Main Floor;Manifold 2;Living Room	Coil 3	1,000
A-9	213	Main Floor;Manifold 2;Living Room	Coil 3	1,000
A-10	213	Main Floor;Manifold 2;Living Room	Coil 3	1,000
A-12	179	Main Floor;Manifold 1;Entry	Coil 1	1,000
A-13	101	Main Floor;Manifold 2;Kitchen	Coil 3	1,000
A-14	166	Main Floor;Manifold 1;Primary Bedroom	Coil 1	1,000

use leftover from upstairs 1000' roll



Downstairs radiant layout

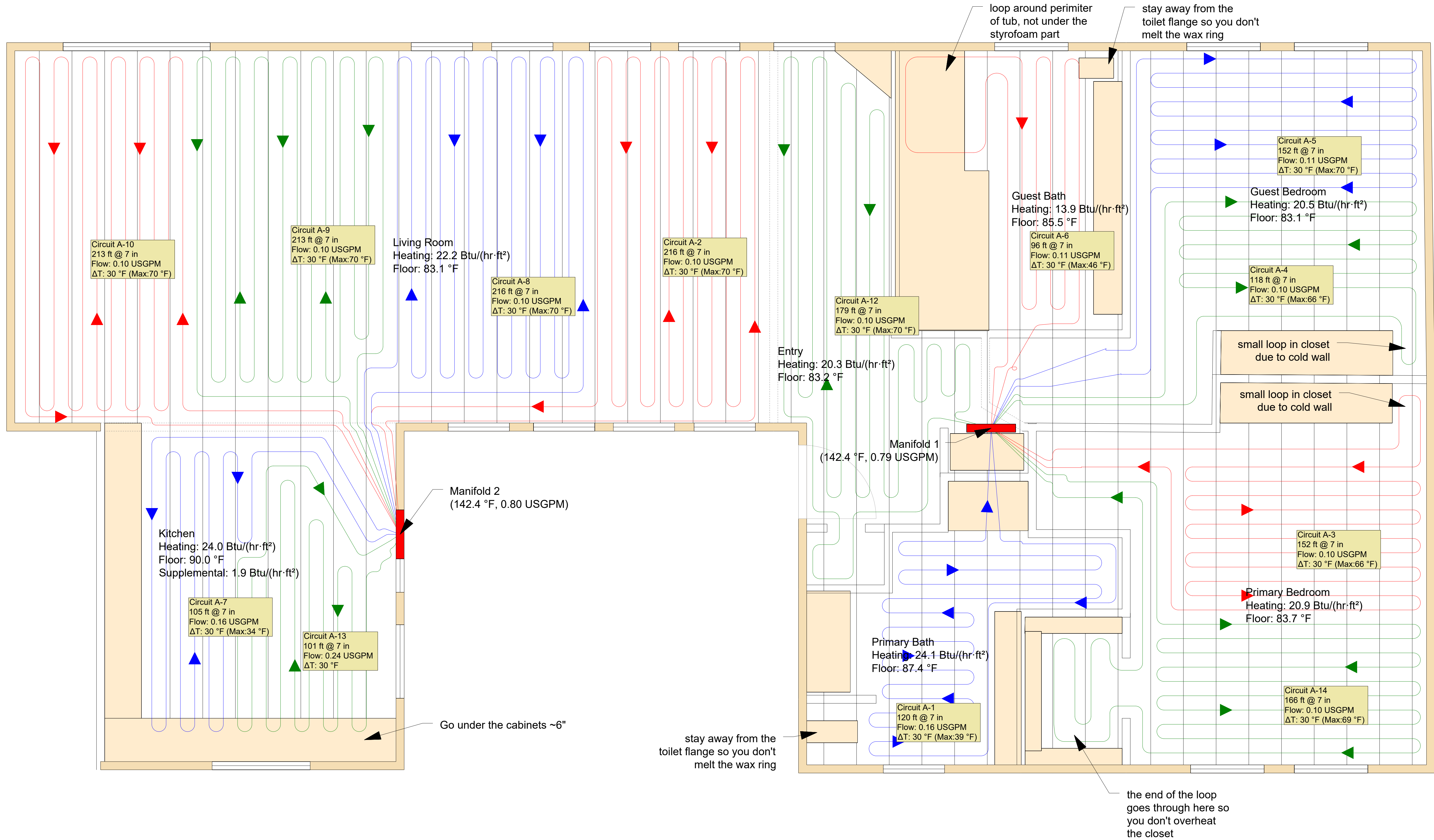

Note: Details of the tubing bend radius have been simplified for clarity. Consult tubing manufacturer for specific bend radius recommendations.



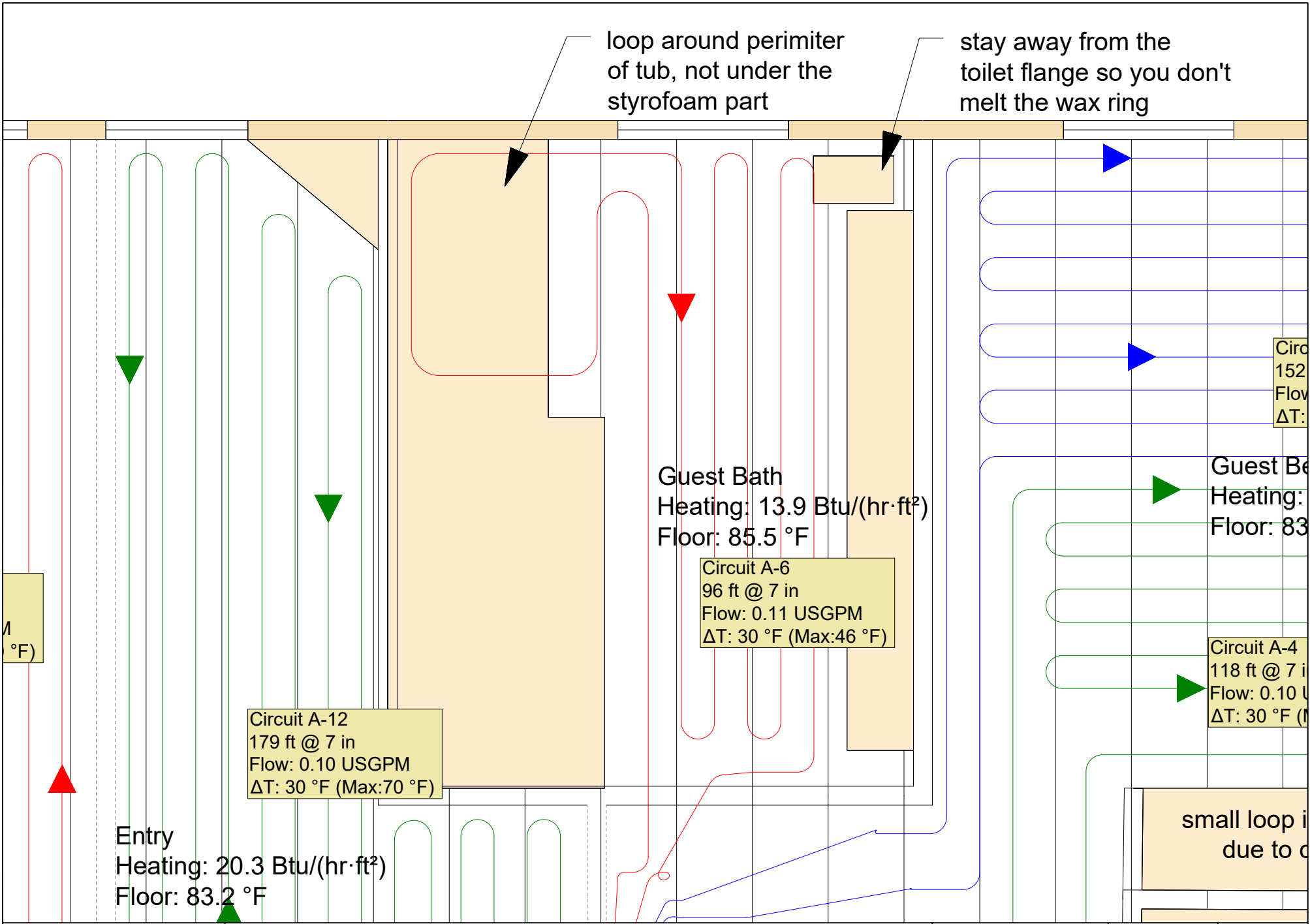

Note: Details of the tubing bend radius have been simplified for clarity. Consult tubing manufacturer for specific bend radius recommendations.



Project Number: 611 W 11th Downstairs	Scale: Not To scale	Date: 1/19/2018
Drawing: Guest Bath	Page: 1	

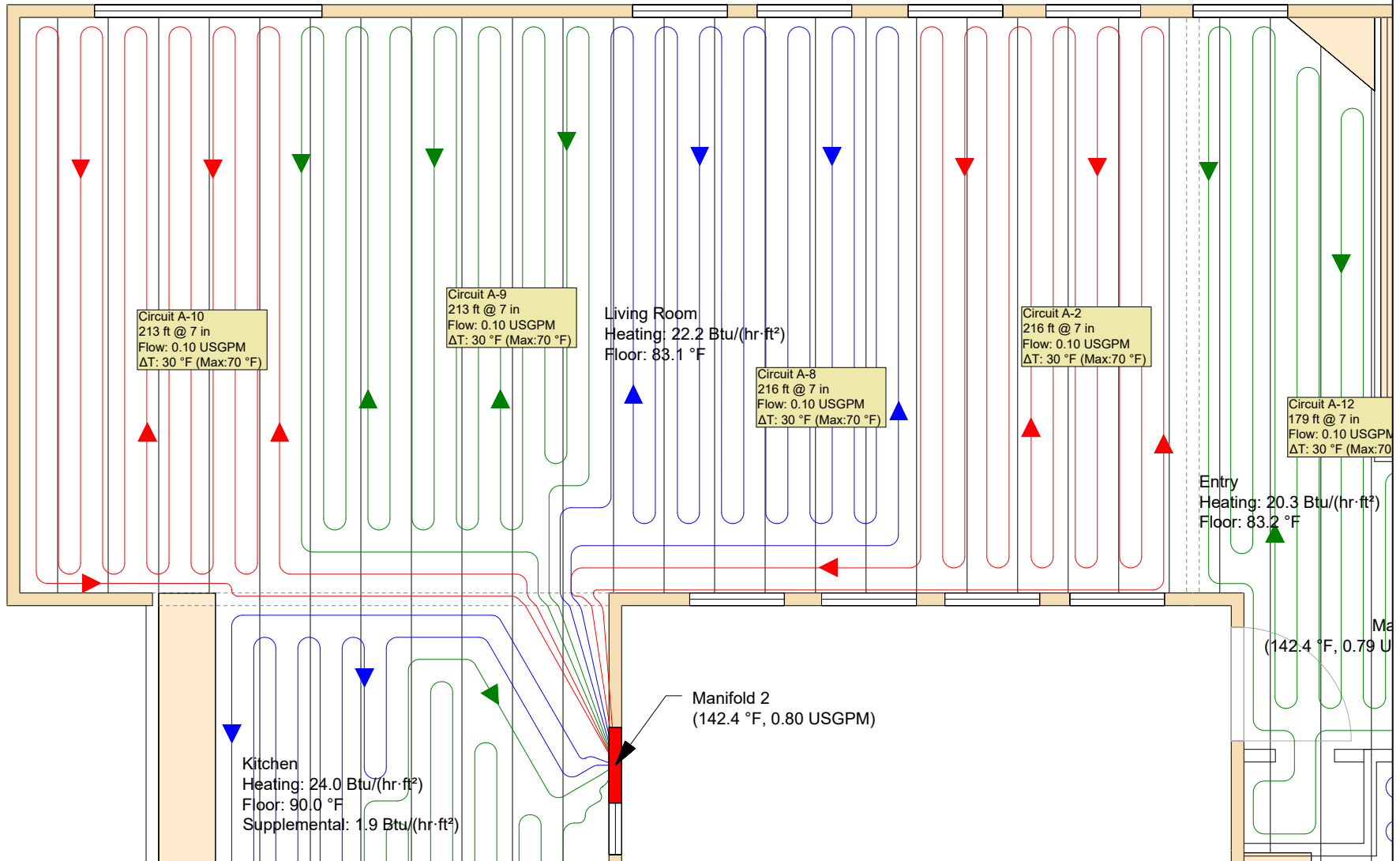

Circuit A-10
213 ft @ 7 in
Flow: 0.10 USGPM
ΔT: 30 °F (Max:70 °F)

Circuit A-9
213 ft @ 7 in
Flow: 0.10 USGPM
ΔT: 30 °F (Max:70 °F)

Living Room
Heating: 22.2 Btu/(hr-ft²)
Floor: 83.1 °F

Circuit A-8
216 ft @ 7 in
Flow: 0.10 USGPM
ΔT: 30 °F (Max:70 °F)

Circuit A-2
216 ft @ 7 in
Flow: 0.10 USGPM
ΔT: 30 °F (Max:70 °F)

Circuit A-12
179 ft @ 7 in
Flow: 0.10 USGPM
ΔT: 30 °F (Max:70 °F)

Entry
Heating: 20.3 Btu/(hr-ft²)
Floor: 83.2 °F

Manifold 2
(142.4 °F, 0.80 USGPM)

Kitchen
Heating: 24.0 Btu/(hr-ft²)
Floor: 90.0 °F
Supplemental: 1.9 Btu/(hr-ft²)

Note: Details of the tubing bend radius have been simplified for clarity. Consult tubing manufacturer for specific bend radius recommendations.



Project Number: 611 W 11th Downstairs	Scale: 1/4"=1'	Date: 1/19/2018
Drawing: Living Room	Page: 2	

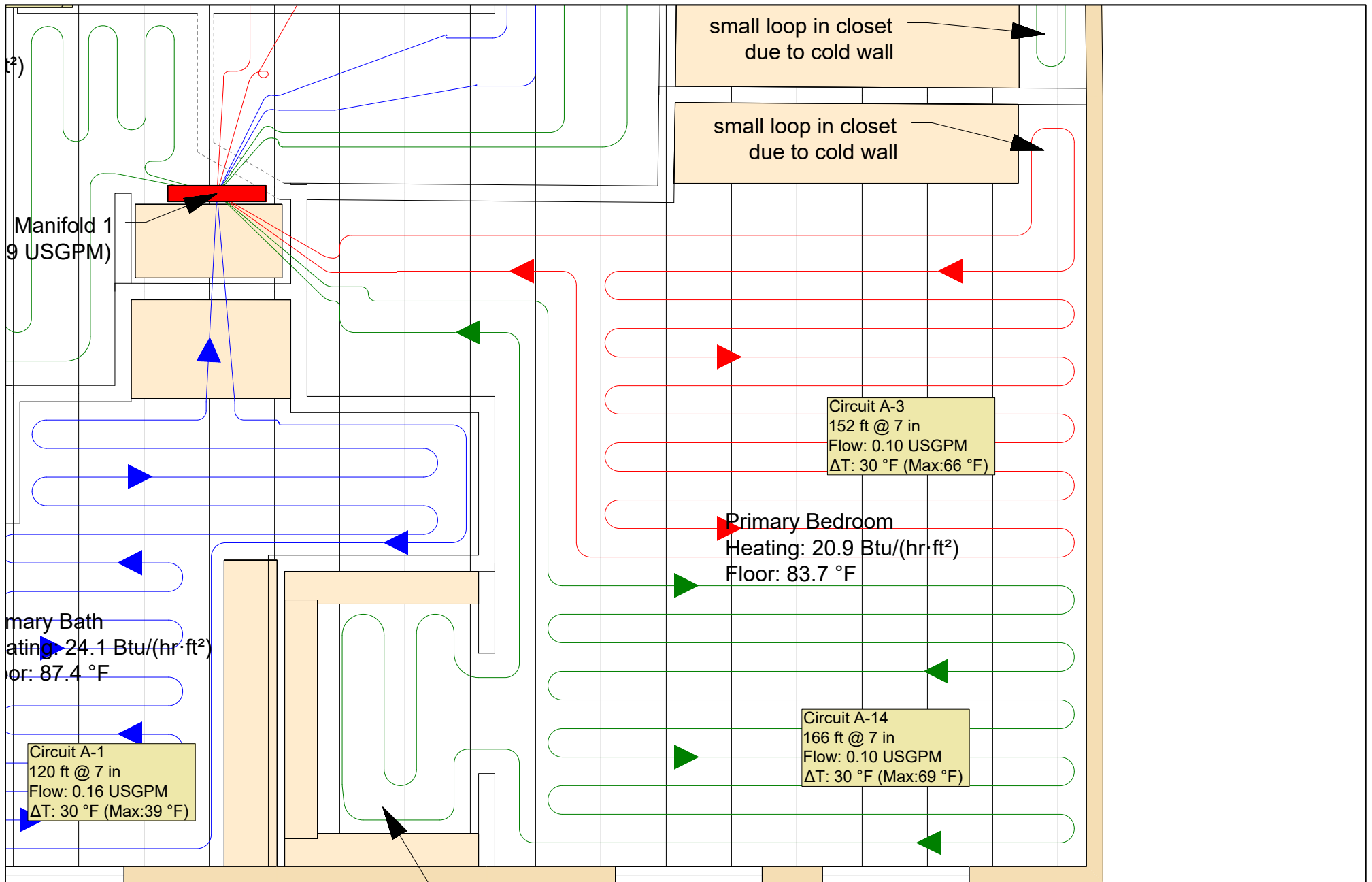

the end of the loop goes through here so



Note: Details of the tubing bend radius have been simplified for clarity. Consult tubing manufacturer for specific bend radius recommendations.

Project Number:
611 W 11th Downstairs
Drawing:
Primary Bedroom

Scale:
3/8"=1'
Page:
3

Date:
1/19/2018
N

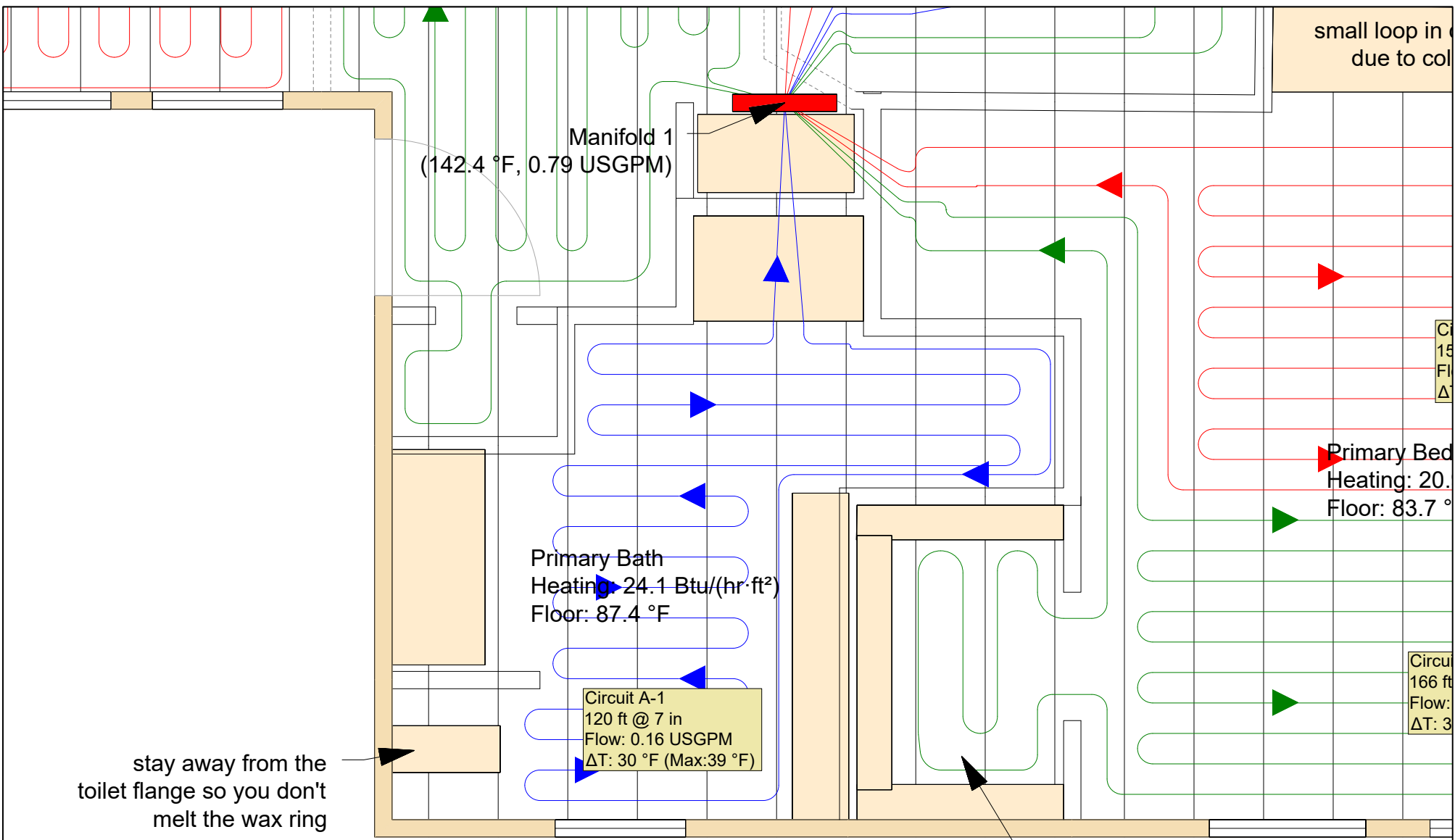

small loop in
due to col

Manifold 1
(142.4 °F, 0.79 USGPM)

Primary Bath
Heating: 24.1 Btu/(hr·ft²)
Floor: 87.4 °F

Circuit A-1
120 ft @ 7 in
Flow: 0.16 USGPM
ΔT: 30 °F (Max: 39 °F)

Primary Bed
Heating: 20.0
Floor: 83.7 °F

Circuit
15
Flow:
ΔT:

Circuit
166 ft
Flow:
ΔT: 3

stay away from the
toilet flange so you don't
melt the wax ring

the end of the loop
goes through here so
you don't overheat
the closet

Note: Details of the tubing bend radius have been simplified for clarity. Consult tubing manufacturer for specific bend radius recommendations.



Project Number: 611 W 11th Downstairs	Scale: 3/8"=1'	Date: 1/19/2018
Drawing: Primary Bath	Page: 4	

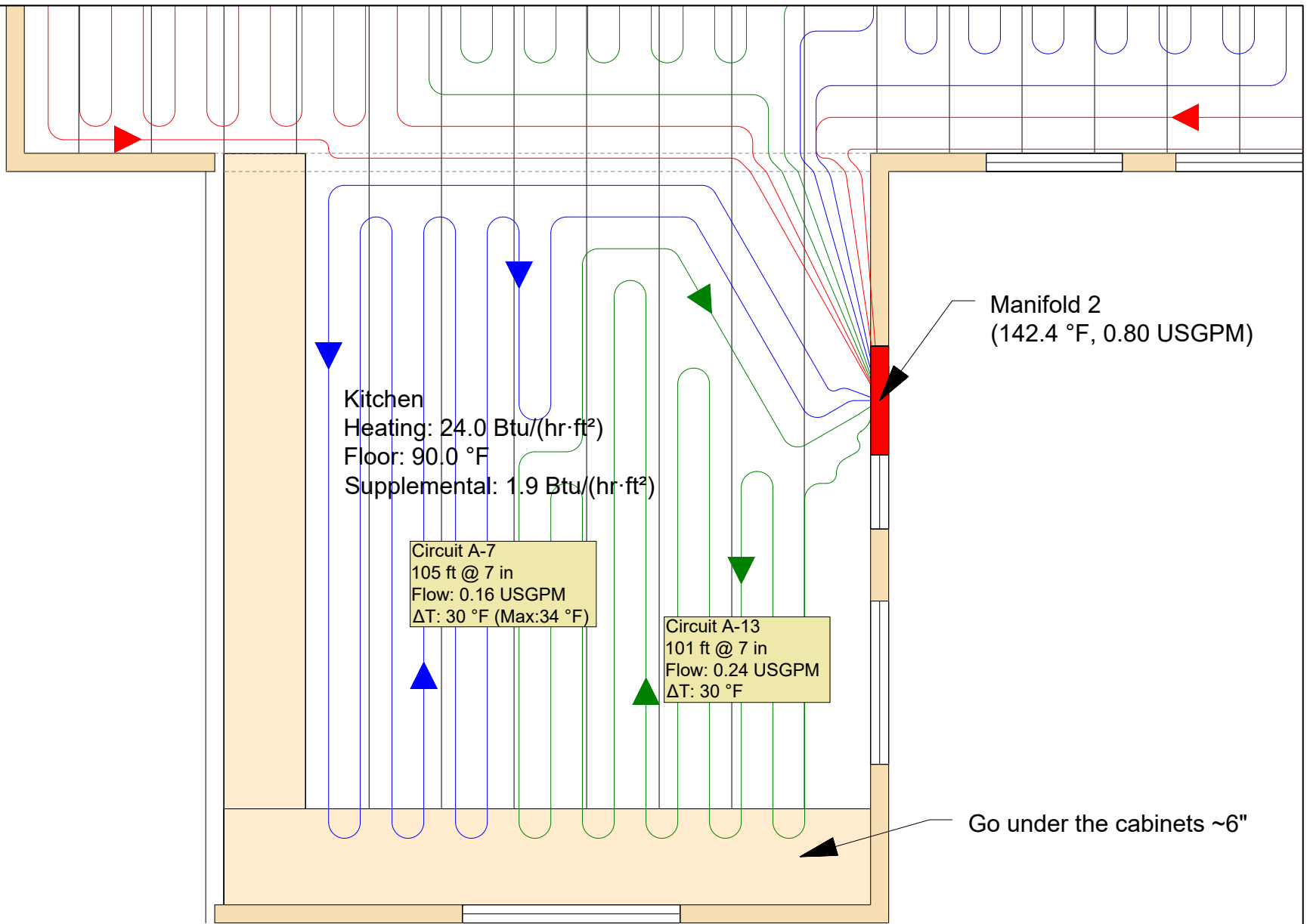

Kitchen
 Heating: 24.0 Btu/(hr·ft²)
 Floor: 90.0 °F
 Supplemental: 1.9 Btu/(hr·ft²)

Circuit A-7
 105 ft @ 7 in
 Flow: 0.16 USGPM
 ΔT: 30 °F (Max:34 °F)

Circuit A-13
 101 ft @ 7 in
 Flow: 0.24 USGPM
 ΔT: 30 °F

Go under the cabinets ~6"

Note: Details of the tubing bend radius have been simplified for clarity. Consult tubing manufacturer for specific bend radius recommendations.



Project Number: 611 W 11th Downstairs	Scale: 3/8"=1'	Date: 1/19/2018
Drawing: Kitchen	Page: 5	

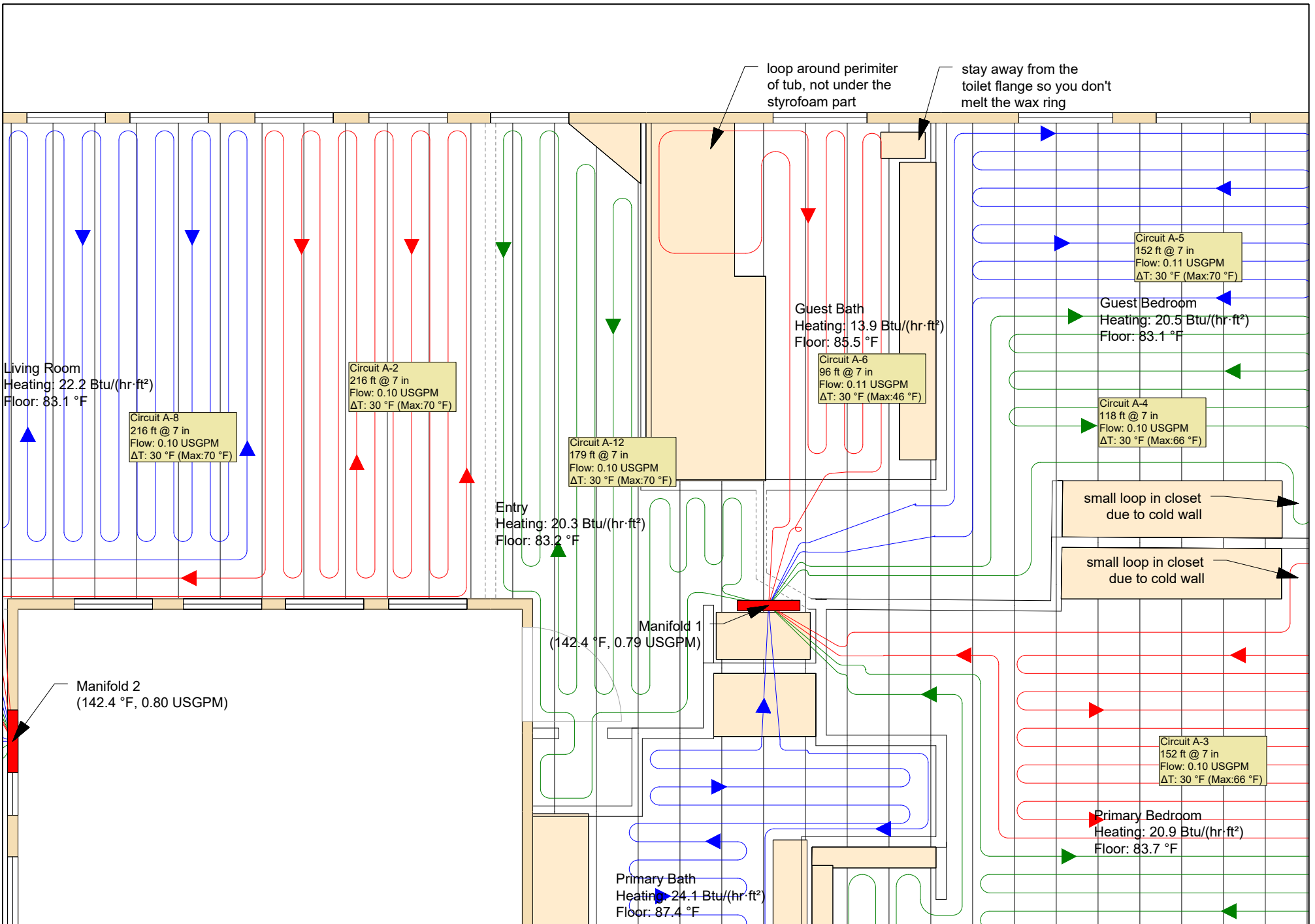

Note: Details of the tubing bend radius have been simplified for clarity. Consult tubing manufacturer for specific bend radius recommendations.



Project Number: 611 W 11th Downstairs	Scale: 1/4"=1'	Date: 1/19/2018
Drawing: Entry	Page: 6	

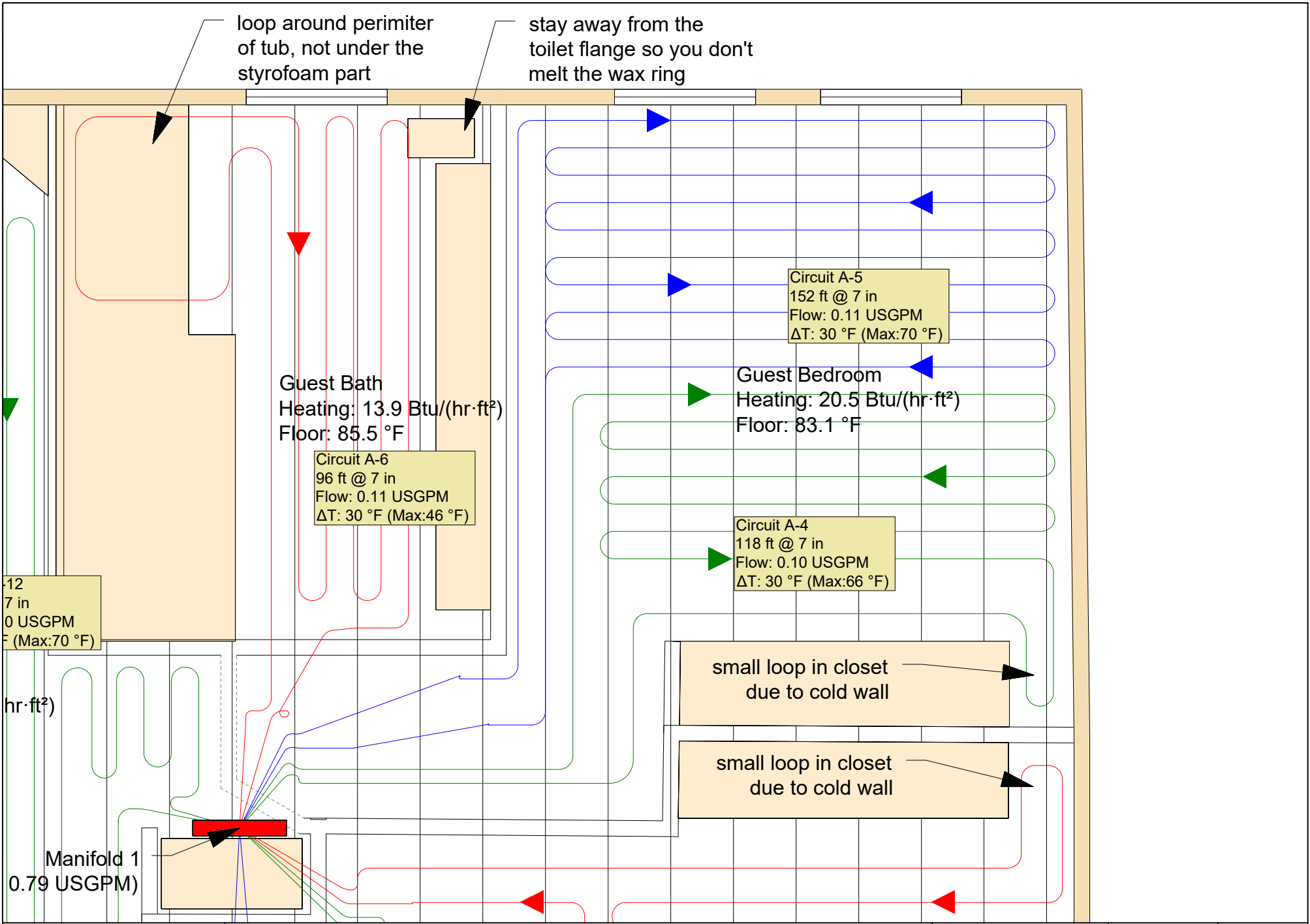

Project Number: 611 W 11th Downstairs	Scale: 3/8"=1'	Date: 1/19/2018
Drawing: Guest Bedroom	Page: 7	



Heating System Summary

Project #:611 W 11th Downstairs
January 19, 2018

Project Information

Project #: 611 W 11th Downstairs
Name:
Location:

Notes:

Project Summary

Load Calculation Method:	Manual J8	Total Circuit Lengths:		Component Losses:	14,334 Btu/hr
Design Location:	Anchorage IAP, Alaska	hePEX 5/16"	2,045 ft	Infiltration/Ventilation:	14,437 Btu/hr
Outdoor Temperature:	-4.0 °F			Radiant Back Losses:	12,968 Btu/hr
Floorplans / Levels:		Total RH Circuits:	13	Total Heating Load:	41,739 Btu/hr
Main Floor	1,455 ft ²	Total Manifolds:	2		
Total Area:	1,455 ft ²	Total Zones:	1	Radiant Heating:	28,464 Btu/hr
		Fluid Type:	100% Water	Radiant Back Losses:	12,968 Btu/hr
		Total Tubing Volume:	7.11 USG	Other:	307 Btu/hr
		Surface Temperature:	84 - 90 °F	Total Heating Load:	41,739 Btu/hr

Zone Heating Summary

Zone #	Gross Area	Construction	Heating Types	RH ¹ Circuits	Total Tubing	Manifolds	Flowrate	Head Loss (Circuit Only)	RH Load ²	Supplemental	Zone Load ³
Zone 101	1,455	Quik Trak Above Sub-Floor	RH,OTH	13	2,045	2	1.59	2.9	41,432	307	41,739

(1) Complete circuits assigned to this zone. (2) Total Radiant heating load for rooms in zone, including all panel back loss. (3) Total load for zone including all panel back loss. Does not account for reclaimed loss within building envelope.

Length = ft Area = ft² Temperature = °F Flowrate = USGPM Air Flow = cfm Heat Loss = Btu/hr Unit Heat Loss = Btu/(hr-ft²) Rv = hr-ft²-°F/btu
Head Loss = ft water RH = Radiant Floor Heating BB = Baseboard FA = Forced Air OTH = Other Heating SM = Snowmelt N = Not Heated

Created Using LoopCAD 2022 Uponor(US) (3/3/2026)
Version:22.0.0994 R (Trial)

See end of report for important Notes and Disclaimers.

Room Heating Summary (By Construction Type)

Quik Trak Above Sub-Floor

Zone #	Room Name	Heating Type	Floor Area	Heated Area	Manifold #	Tube Size	RH Circuits ¹	Tube Spacing	Tubing In Room	Floor Cover RV	Required Temp.	Unit RH Load	RH Load ²	Supplemental	Total Load ³
Zone 101	Entry	RH	121	110	Manifold 1	5/16"	1	7	180	0.5	118	32.0	3,515	0	3,515
Zone 101	Guest Bath	RH	103	53	Manifold 1	5/16"	1	7	71	0.5	134	43.9	2,342	0	2,342
Zone 101	Guest Bedroom	RH	185	171	Manifold 1	5/16"	2	7	263	0.5	122	40.9	6,987	0	6,987
Zone 101	Kitchen	RH, OTH	160	100	Manifold 2	5/16"	2	7	210	0.5	142	66.0	6,622	307	6,929
Zone 101	Living Room	RH	468	468	Manifold 2	5/16"	4	7	787	0.5	118	26.4	12,332	0	12,332
Zone 101	Primary Bath	RH	92	72	Manifold 1	5/16"	1	7	105	0.5	138	42.8	3,088	0	3,088
Zone 101	Primary Bedroom	RH	222	198	Manifold 1	5/16"	2	7	297	0.5	124	33.1	6,547	0	6,547

(1) Circuits assigned to this room. Leaders from other rooms may not be counted. (2) Includes panel back loss. (3) Total load including panel back loss. Does not account for reclaimed loss within building envelope.

Manifold Summary

Manifold Name	# Zones	# Circuits	Flow	Head Loss ¹	Required Temp.	Supplied Temp.	Temp Drop	Manifold Type	Control Type	# Actuators	S/R Length ²	S/R Pipe
Manifold 1	1	7	0.79	1.9	138	142	30 (70)	TruFLOW Jr Valved w/ Balancing	Manifold	0	-	-
Manifold 2	1	6	0.80	3.0	142	142	30 (70)	TruFLOW Jr Valved w/ Balancing	Manifold	0	-	-
Total	1	13	1.59	3.0	-	-	-	-	-	0	-	-

(1) Total Head loss includes manifold, circuits and supply/return piping if specified. (2) S/R Length = one way

Name:

Project #:611 W 11th Downstairs

Heating System Summary

January 19, 2018

Disclaimers

With the permission of the Air Conditioning Contractors of America ("ACCA"), material is reproduced from Manual J Residential Load Calculation (8th Edition) which is copyrighted by ACCA. The program and data are provided "as is" without warranty of any kind either expressed or implied. The entire risk as the quality and performance of the program and data is with you. In no event will ACCA be liable to you for any damages, including without limitation any lost profits, lost savings, or other incidental or consequential damages arising out of the use or inability to use this program or the data. © 2015 Air Conditioning Contractors of America. All Rights Reserved. www.acca.org

ACCA, Manual J and Powered by ACCA Manual J are registered trademarks of the Air Conditioning Contractors of America. All rights reserved.

Cold weather humidification, or some lifestyles that produce excessive moisture, may cause condensation to occur if the absolute humidity of the indoor air is too high for the momentary circumstances. Condensation can occur on surfaces or concealed within the structure, and can lead to mold, mildew, frost damage, and moisture damage. The software does not perform calculations for the estimation or detection of possible condensation problems, and it is the designers (i.e. software users) responsibility to do so independently if required. For guidance and additional cautions refer to ACCA Manual J 8th Edition, including Section 1-11 and Section 27.

The calculated values shown in this report are based on the data input by the user of the software. Inaccurate or erroneous data input will result in inaccurate or erroneous results. You are strongly advised to review all input data carefully, and to have the calculated results reviewed by an experienced heating professional to ensure reasonableness and suitability for your application.

IN NO EVENT WILL AVENIR SOFTWARE INC. ("AVENIR") OR ITS AFFILIATES BE LIABLE UNDER ANY CONTRACT, NEGLIGENCE, STRICT LIABILITY OR OTHER LEGAL OR EQUITABLE THEORY FOR ANY CONSEQUENTIAL, INCIDENTAL, INDIRECT OR SPECIAL OR PUNITIVE DAMAGES WHATSOEVER (INCLUDING, BUT NOT LIMITED TO, DAMAGES FOR LOSS OF BUSINESS PROFITS, BUSINESS INTERRUPTION, LOSS OF BUSINESS INFORMATION OR DATA AND THE LIKE), EVEN IF SUCH PARTY HAS BEEN ADVISED OF THE POSSIBILITY OF SUCH DAMAGES. AVENIR'S CUMULATIVE LIABILITY FROM ANY CAUSE RELATED TO OR ARISING FROM THE USE THIS REPORT, AND REGARDLESS OF THE FORM OF THE ACTION, SHALL BE LIMITED TO NO GREATER THAN THE AMOUNT OF FEES PAID TO AVENIR UNDER THE SOFTWARE LICENSE AGREEMENT.

Length = ft Area = ft² Temperature = °F Flowrate = USGPM Air Flow = cfm Heat Loss = Btu/hr Unit Heat Loss = Btu/(hr-ft²) Rv = hr-ft²-°F/btu
Head Loss = ft water RH = Radiant Floor Heating BB = Baseboard FA = Forced Air OTH = Other Heating SM = Snowmelt N = Not Heated

Created Using LoopCAD 2022 Uponor(US) (3/3/2026)
Version:22.0.0994 R (Trial)

See end of report for important Notes and Disclaimers.

Page 3 of 3



Heating System Detail

Project #:611 W 11th Downstairs
January 19, 2018

Project Information

Project #: 611 W 11th Downstairs
Name:
Location:

Notes:

Design Conditions and Summary

Load Calculation Method:	Manual J8	Total Tubing Lengths:		Component Losses:	14,334 Btu/hr
Design Location:	Anchorage IAP, Alaska	hePEX 5/16"	2,045 ft	Infiltration/Ventilation:	14,437 Btu/hr
Outdoor Temperature:	-4.0 °F			Radiant Back Losses:	12,968 Btu/hr
Floorplans / Levels:		Total RH Circuits:	13	Total Heating Load:	41,739 Btu/hr
Main Floor	1,455 ft ²	Total Manifolds:	2		
Total Area:	1,455 ft ²	Total Zones:	1	Radiant Heating:	28,464 Btu/hr
		Fluid Type:	100% Water	Radiant Back Losses:	12,968 Btu/hr
		Total Tubing Volume:	7.11 USG	Other:	307 Btu/hr
				Total Heating Load:	41,739 Btu/hr

Zone Heating Summary

Zone #	Area	Heating Types	RH Circuits	Flowrate	Head Loss	Supplemental	Rooms
101	1,455	RH,OTH	13	1.59	3.0	307	Guest Bath, Living Room, Primary Bedroom, Primary Bath, Kitchen, Entry, Guest Bedroom
Total	1,455	RH,OTH	13	1.59	3.0	307	

*RH Loads include internal panel back loss that may not be included in the project total.

Length = ft Area = ft² Temperature = °F Flowrate = USGPM Air Flow = cfm Heat Loss = Btu/hr Unit Heat Loss = Btu/(hr-ft²) Rv = hr-ft²-°F/btu
Head Loss = ft water RH = Radiant Floor Heating BB = Baseboard FA = Forced Air OTH = Other Heating SM = Snowmelt N = Not Heated

Created Using LoopCAD 2022 Uponor(US) (3/3/2026)
Version:22.0.0994 R (Trial)

See end of report for important Notes and Disclaimers.

Room Heating Summary

Main Floor

Entry

Total Area: 134 ft²
Heated by: RH
Room Temperature: 72 °F
Floor Covering (RV): 0.5

Radiant Heating:
Heated Area: 110 ft²
Tubing in Floor: 186 ft
Circuits in Room: 1
Tube Spacing: 7
Required Surface Temp: 83 °F
Required Water Temp: 118 °F
Est. Peak Output: 2,689 Btu/hr

Load/Loss Summary:
Room Design Load: 2,455 Btu/hr

Radiant Load: 3,515 Btu/hr
Baseboard Load: 0 Btu/hr
Forced Air Load: 0 Btu/hr
Other Load: 0 Btu/hr

Radiant Back Loss: 1,060 Btu/hr
Recovered Back Loss: 0 Btu/hr
Total Heat Loss: 3,515 Btu/hr

Guest Bath

Total Area: 112 ft²
Heated by: RH
Room Temperature: 72 °F
Floor Covering (RV): 0.5

Radiant Heating:
Heated Area: 53 ft²
Tubing in Floor: 74 ft
Circuits in Room: 1
Tube Spacing: 7
Required Surface Temp: 85 °F
Required Water Temp: 134 °F
Est. Peak Output: 1,437 Btu/hr

Load/Loss Summary:
Room Design Load: 1,437 Btu/hr

Radiant Load: 2,342 Btu/hr
Baseboard Load: 0 Btu/hr
Forced Air Load: 0 Btu/hr
Other Load: 0 Btu/hr

Radiant Back Loss: 905 Btu/hr
Recovered Back Loss: 0 Btu/hr
Total Heat Loss: 2,342 Btu/hr

Guest Bedroom

Total Area: 200 ft²
Heated by: RH
Room Temperature: 72 °F
Floor Covering (Rv): 0.5

Radiant Heating:
Heated Area: 171 ft²
Tubing in Floor: 270 ft
Circuits in Room: 2
Tube Spacing: 7
Required Surface Temp: 83 °F
Required Water Temp: 122 °F
Est. Peak Output: 4,134 Btu/hr

Load/Loss Summary:
Room Design Load: 3,782 Btu/hr
Radiant Load: 6,987 Btu/hr
Baseboard Load: 0 Btu/hr
Forced Air Load: 0 Btu/hr
Other Load: 0 Btu/hr
Radiant Back Loss: 3,205 Btu/hr
Recovered Back Loss: 0 Btu/hr
Total Heat Loss: 6,987 Btu/hr

Kitchen

Total Area: 173 ft²
Heated by: RH,OTH
Room Temperature: 72 °F
Floor Covering (Rv): 0.5

Radiant Heating:
Heated Area: 100 ft²
Tubing in Floor: 215 ft
Circuits in Room: 2
Tube Spacing: 7
Required Surface Temp: 90 °F
Required Water Temp: 142 °F
Est. Peak Output: 3,546 Btu/hr

Supplemental Req'd: 307 Btu/hr

Load/Loss Summary:
Room Design Load: 3,546 Btu/hr
Radiant Load: 6,622 Btu/hr
Baseboard Load: 0 Btu/hr
Forced Air Load: 0 Btu/hr
Other Load: 307 Btu/hr
Radiant Back Loss: 3,075 Btu/hr
Recovered Back Loss: 0 Btu/hr
Total Heat Loss: 6,929 Btu/hr

Living Room

Total Area: 494 ft²
Heated by: RH
Room Temperature: 72 °F
Floor Covering (Rv): 0.5

Radiant Heating:
Heated Area: 468 ft²
Tubing in Floor: 801 ft
Circuits in Room: 4
Tube Spacing: 7
Required Surface Temp: 83 °F
Required Water Temp: 118 °F
Est. Peak Output: 11,837 Btu/hr

Load/Loss Summary:
Room Design Load: 10,374 Btu/hr
Radiant Load: 12,332 Btu/hr
Baseboard Load: 0 Btu/hr
Forced Air Load: 0 Btu/hr
Other Load: 0 Btu/hr
Radiant Back Loss: 1,958 Btu/hr
Recovered Back Loss: 0 Btu/hr
Total Heat Loss: 12,332 Btu/hr

Primary Bath

Total Area: 103 ft²
Heated by: RH
Room Temperature: 72 °F
Floor Covering (RV): 0.5

Radiant Heating:
Heated Area: 72 ft²
Tubing in Floor: 110 ft
Circuits in Room: 1
Tube Spacing: 7
Required Surface Temp: 87 °F
Required Water Temp: 138 °F
Est. Peak Output: 2,223 Btu/hr

Load/Loss Summary:
Room Design Load: 2,223 Btu/hr
Radiant Load: 3,088 Btu/hr
Baseboard Load: 0 Btu/hr
Forced Air Load: 0 Btu/hr
Other Load: 0 Btu/hr
Radiant Back Loss: 865 Btu/hr
Recovered Back Loss: 0 Btu/hr
Total Heat Loss: 3,088 Btu/hr

Primary Bedroom

Total Area: 240 ft²
Heated by: RH
Room Temperature: 72 °F
Floor Covering (RV): 0.5

Radiant Heating:
Heated Area: 198 ft²
Tubing in Floor: 305 ft
Circuits in Room: 2
Tube Spacing: 7
Required Surface Temp: 84 °F
Required Water Temp: 124 °F
Est. Peak Output: 4,762 Btu/hr

Load/Loss Summary:
Room Design Load: 4,646 Btu/hr
Radiant Load: 6,547 Btu/hr
Baseboard Load: 0 Btu/hr
Forced Air Load: 0 Btu/hr
Other Load: 0 Btu/hr
Radiant Back Loss: 1,900 Btu/hr
Recovered Back Loss: 0 Btu/hr
Total Heat Loss: 6,547 Btu/hr

Radiant Heating Details
Manifold Summary

Manifold Name	Zones	Circuits	Flowrate	Head Loss ¹	Required Temp.	Supplied Temp.	Temp Drop	Manifold Type	Control Type	Actuators	S/R Length ²	S/R Pipe
Manifold 1	1	7	0.79	1.9	138	142	30 (70)	TruFLOW Jr Valved w/ Balancing	Manifold	0	-	-
Manifold 2	1	6	0.80	3.0	142	142	30 (70)	TruFLOW Jr Valved w/ Balancing	Manifold	0	-	-
Total	1	13	1.59	3.0	142	-	-	-	-	0	-	-

(1) Total Head loss includes manifold, circuits and supply/return piping if specified., (2) S/R Length = one way

Tubing Circuit Details

Manifold 1

Circuit	Rooms Served	Total Length	Tube Spacing	Area Covered	Tubing	Flowrate	Head Loss ¹	Temp Drop	Load	Actuator	Valve Setting
A-1	Primary Bath	120	7	73	hePEX 5/16"	0.16	1.8	30 (39)	3,115	No	4.2
A-3	Primary Bedroom	152	7	98	hePEX 5/16"	0.10	1.0	30 (66)	3,232	No	0.48
A-4	Guest Bedroom	118	7	78	hePEX 5/16"	0.10	0.8	30 (66)	3,179	No	0.47
A-5	Guest Bedroom	152	7	89	hePEX 5/16"	0.11	1.2	30 (70)	3,662	No	0.53
A-6	Guest Bath	96	7	57	hePEX 5/16"	0.11	0.8	30 (46)	2,504	No	0.47
A-12	Entry	179	7	107	hePEX 5/16"	0.10	1.3	30 (70)	3,443	No	0.55
A-14	Primary Bedroom	166	7	101	hePEX 5/16"	0.10	1.1	30 (69)	3,343	No	0.49
Total	-	981		604	-	0.79	1.8		22,478	0	

(1) Head loss for circuit tubing only

Manifold 2

Circuit	Rooms Served	Total Length	Tube Spacing	Area Covered	Tubing	Flowrate	Head Loss ¹	Temp Drop	Load	Actuator	Valve Setting
A-2	Living Room	216	7	117	hePEX 5/16"	0.10	1.5	30 (70)	3,122	No	0.44
A-7	Kitchen	105	7	41	hePEX 5/16"	0.16	1.6	30 (34)	2,736	No	0.49
A-8	Living Room	216	7	125	hePEX 5/16"	0.10	1.6	30 (70)	3,336	No	0.45
A-9	Living Room	213	7	117	hePEX 5/16"	0.10	1.5	30 (70)	3,144	No	0.43
A-10	Living Room	213	7	114	hePEX 5/16"	0.10	1.4	30 (70)	3,102	No	0.43
A-13	Kitchen	101	7	53	hePEX 5/16"	0.24	2.9	30 (30)	3,514	No	4.2
Total	-	1,064		568	-	0.80	2.9		18,954	0	

(1) Head loss for circuit tubing only

Name:

Project #:611 W 11th Downstairs

Heating System Detail

January 19, 2018

Disclaimers

With the permission of the Air Conditioning Contractors of America ("ACCA"), material is reproduced from Manual J Residential Load Calculation (8th Edition) which is copyrighted by ACCA. The program and data are provided "as is" without warranty of any kind either expressed or implied. The entire risk as the quality and performance of the program and data is with you. In no event will ACCA be liable to you for any damages, including without limitation any lost profits, lost savings, or other incidental or consequential damages arising out of the use or inability to use this program or the data. © 2015 Air Conditioning Contractors of America. All Rights Reserved. www.acca.org

ACCA, Manual J and Powered by ACCA Manual J are registered trademarks of the Air Conditioning Contractors of America. All rights reserved.

Cold weather humidification, or some lifestyles that produce excessive moisture, may cause condensation to occur if the absolute humidity of the indoor air is too high for the momentary circumstances. Condensation can occur on surfaces or concealed within the structure, and can lead to mold, mildew, frost damage, and moisture damage. The software does not perform calculations for the estimation or detection of possible condensation problems, and it is the designers (i.e. software users) responsibility to do so independently if required. For guidance and additional cautions refer to ACCA Manual J 8th Edition, including Section 1-11 and Section 27.

The calculated values shown in this report are based on the data input by the user of the software. Inaccurate or erroneous data input will result in inaccurate or erroneous results. You are strongly advised to review all input data carefully, and to have the calculated results reviewed by an experienced heating professional to ensure reasonableness and suitability for your application.

IN NO EVENT WILL AVENIR SOFTWARE INC. ("AVENIR") OR ITS AFFILIATES BE LIABLE UNDER ANY CONTRACT, NEGLIGENCE, STRICT LIABILITY OR OTHER LEGAL OR EQUITABLE THEORY FOR ANY CONSEQUENTIAL, INCIDENTAL, INDIRECT OR SPECIAL OR PUNITIVE DAMAGES WHATSOEVER (INCLUDING, BUT NOT LIMITED TO, DAMAGES FOR LOSS OF BUSINESS PROFITS, BUSINESS INTERRUPTION, LOSS OF BUSINESS INFORMATION OR DATA AND THE LIKE), EVEN IF SUCH PARTY HAS BEEN ADVISED OF THE POSSIBILITY OF SUCH DAMAGES. AVENIR'S CUMULATIVE LIABILITY FROM ANY CAUSE RELATED TO OR ARISING FROM THE USE THIS REPORT, AND REGARDLESS OF THE FORM OF THE ACTION, SHALL BE LIMITED TO NO GREATER THAN THE AMOUNT OF FEES PAID TO AVENIR UNDER THE SOFTWARE LICENSE AGREEMENT.

Length = ft Area = ft² Temperature = °F Flowrate = USGPM Air Flow = cfm Heat Loss = Btu/hr Unit Heat Loss = Btu/(hr-ft²) Rv = hr-ft²-°F/btu
Head Loss = ft water RH = Radiant Floor Heating BB = Baseboard FA = Forced Air OTH = Other Heating SM = Snowmelt N = Not Heated

Created Using LoopCAD 2022 Uponor(US) (3/3/2026)
Version:22.0.0994 R (Trial)

See end of report for important Notes and Disclaimers.

Page 6 of 6



Water Supply Summary

Project #:611 W 11th Downstairs

January 19, 2018

Project Information

Project #: 611 W 11th Downstairs

Notes:

Name:

Location:

Supply Summary

Name	Temp	Total Fluid Vol	Total Flow	Head Loss ¹	Load ²	# Circuits	# Zones
Water Temperature	142	7.11	1.59	3.0	41,432	13	1

(1) Head loss includes manifolds, circuits, and supply/return piping if specified, may also contain control valve losses. (2) Load includes all panel back losses.

Manifold Summary

Manifold Name	Circuits	Flowrate	Required Temp.	Supplied Temp.	Manifold Type	S/R Length ¹	S/R Pipe	Manifold Head Loss	Circuit Head Loss	S/R Head Loss	Total Head Loss ²
Manifold 1	7	0.79	138	142	TruFLOW Jr Valved w/ Balancing	-	-	0.0	1.8	0.0	1.9
Manifold 2	6	0.80	142	142	TruFLOW Jr Valved w/ Balancing	-	-	0.0	2.9	0.0	3.0
Total	13	1.59	-	-	-	-	-	0.0	2.9	0.0	3.0

(1) S/R Length = one way, (2) Total Head loss includes manifold, circuits and supply/return piping if specified.

Name:

Project #:611 W 11th Downstairs

Water Supply Summary

January 19, 2018

Water Temperature (142 °F)**Manifold 1 (142 °F, TruFLOW Jr Valved w/ Balancing, 7 Circuits)**

Circuit	Rooms Served	Total Length	Tube Spacing	Area Covered	Tubing	Flowrate	Head Loss ¹	Temp Drop ²	Load ³	Actuator	Valve Setting
A-1	Primary Bath	120	7	73	hePEX 5/16"	0.16	1.8	30 (39)	3,115	No	4.2
A-3	Primary Bedroom	152	7	98	hePEX 5/16"	0.10	1.0	30 (66)	3,232	No	0.48
A-4	Guest Bedroom	118	7	78	hePEX 5/16"	0.10	0.8	30 (66)	3,179	No	0.47
A-5	Guest Bedroom	152	7	89	hePEX 5/16"	0.11	1.2	30 (70)	3,662	No	0.53
A-6	Guest Bath	96	7	57	hePEX 5/16"	0.11	0.8	30 (46)	2,504	No	0.47
A-12	Entry	179	7	107	hePEX 5/16"	0.10	1.3	30 (70)	3,443	No	0.55
A-14	Primary Bedroom	166	7	101	hePEX 5/16"	0.10	1.1	30 (69)	3,343	No	0.49
Total	-	981		604	-	0.79	1.8	-	22,478	0	

(1) Head loss for circuit tubing only. (2) Design Temp Drop (Estimated Actual Drop). (3) Required load. Includes panel back losses. Does not reflect maximum capacity of the circuit.

Manifold 2 (142 °F, TruFLOW Jr Valved w/ Balancing, 6 Circuits)

Circuit	Rooms Served	Total Length	Tube Spacing	Area Covered	Tubing	Flowrate	Head Loss ¹	Temp Drop ²	Load ³	Actuator	Valve Setting
A-2	Living Room	216	7	117	hePEX 5/16"	0.10	1.5	30 (70)	3,122	No	0.44
A-7	Kitchen	105	7	41	hePEX 5/16"	0.16	1.6	30 (34)	2,736	No	0.49
A-8	Living Room	216	7	125	hePEX 5/16"	0.10	1.6	30 (70)	3,336	No	0.45
A-9	Living Room	213	7	117	hePEX 5/16"	0.10	1.5	30 (70)	3,144	No	0.43
A-10	Living Room	213	7	114	hePEX 5/16"	0.10	1.4	30 (70)	3,102	No	0.43
A-13	Kitchen	101	7	53	hePEX 5/16"	0.24	2.9	30 (30)	3,514	No	4.2
Total	-	1,064		568	-	0.80	2.9	-	18,954	0	

(1) Head loss for circuit tubing only. (2) Design Temp Drop (Estimated Actual Drop). (3) Required load. Includes panel back losses. Does not reflect maximum capacity of the circuit.

Length = ft Area = ft² Temperature = °F Flowrate = USGPM Heat Loss = Btu/hr Unit Heat Loss = Btu/(hr·ft²) Head Loss = ft water Volume = USGCreated Using LoopCAD 2022 Uponor(US) (3/3/2026)
Version:22.0.0994 R (Trial)**See end of report for important Notes and Disclaimers.**

Page 2 of 3

Disclaimers

With the permission of the Air Conditioning Contractors of America ("ACCA"), material is reproduced from Manual J Residential Load Calculation (8th Edition) which is copyrighted by ACCA. The program and data are provided "as is" without warranty of any kind either expressed or implied. The entire risk as the quality and performance of the program and data is with you. In no event will ACCA be liable to you for any damages, including without limitation any lost profits, lost savings, or other incidental or consequential damages arising out of the use or inability to use this program or the data. © 2015 Air Conditioning Contractors of America. All Rights Reserved. www.acca.org

ACCA, Manual J and Powered by ACCA Manual J are registered trademarks of the Air Conditioning Contractors of America. All rights reserved.

Cold weather humidification, or some lifestyles that produce excessive moisture, may cause condensation to occur if the absolute humidity of the indoor air is too high for the momentary circumstances. Condensation can occur on surfaces or concealed within the structure, and can lead to mold, mildew, frost damage, and moisture damage. The software does not perform calculations for the estimation or detection of possible condensation problems, and it is the designers (i.e. software users) responsibility to do so independently if required. For guidance and additional cautions refer to ACCA Manual J 8th Edition, including Section 1-11 and Section 27.

The calculated values shown in this report are based on the data input by the user of the software. Inaccurate or erroneous data input will result in inaccurate or erroneous results. You are strongly advised to review all input data carefully, and to have the calculated results reviewed by an experienced heating professional to ensure reasonableness and suitability for your application.

IN NO EVENT WILL AVENIR SOFTWARE INC. ("AVENIR") OR ITS AFFILIATES BE LIABLE UNDER ANY CONTRACT, NEGLIGENCE, STRICT LIABILITY OR OTHER LEGAL OR EQUITABLE THEORY FOR ANY CONSEQUENTIAL, INCIDENTAL, INDIRECT OR SPECIAL OR PUNITIVE DAMAGES WHATSOEVER (INCLUDING, BUT NOT LIMITED TO, DAMAGES FOR LOSS OF BUSINESS PROFITS, BUSINESS INTERRUPTION, LOSS OF BUSINESS INFORMATION OR DATA AND THE LIKE), EVEN IF SUCH PARTY HAS BEEN ADVISED OF THE POSSIBILITY OF SUCH DAMAGES. AVENIR'S CUMULATIVE LIABILITY FROM ANY CAUSE RELATED TO OR ARISING FROM THE USE THIS REPORT, AND REGARDLESS OF THE FORM OF THE ACTION, SHALL BE LIMITED TO NO GREATER THAN THE AMOUNT OF FEES PAID TO AVENIR UNDER THE SOFTWARE LICENSE AGREEMENT.

Project Information

Project #: 611 W 11th Downstairs
Name:
Location:

Notes:

Outdoor Conditions

Location: Anchorage IAP, Alaska
Elevation: 131'
Latitude: 61
Dry Bulb: Heating -4.0 °F Cooling 68.0 °F
Daily Range: Low
Wet Bulb: 57.0 °F

Infiltration

Method: Simple
Stories: 1
Construction: Semi-Loose
Exposure Category: Three or Four Exposures
Num Fireplaces: None
Net Air Changes (H/C): 0.72/0.00
Net Flow (H/C): 139 cfm/0 cfm

Indoor Conditions

Room Temp: Heating 72 °F
Design Temp Diff: 76.0 °F
Humidity: 35
Moisture Diff (Grains): -13.0
Ventilation
Num Occupants: 2

Floorplan/Levels

Main Floor 1,455 ft²
Total Heated Area: 1,455 ft²
Total Cooled Area: 0 ft²

Heating

Heat Recovery 0.35
Outside Air: 68 cfm
Sensible Eff: 50 %

Cooling

Heat Recovery
Outside Air: 0 cfm
Sensible Eff: 50 %

Total Heating: 41,739 Btu/hr

Total Sensible: 0 Btu/hr

Total Latent: 0 Btu/hr

Load Breakdown

Name	Heating	Sensible	Latent
Windows*	5,533	0	
Skylights*	0	0	
Doors	0	0	
Walls	8,801	0	
Below Grade Walls	0		
Ceilings	0	0	
Floors	0	0	
Infiltration	11,610	0	0
Internal		0	0
Other	0		
Duct Loads	0	0	0
Ventilation	2,827	0	0
Humidification	0		
Piping Load	0		
Radiant Back Loss	12,968		
Blower Heat		0	
AED*		0	
Total	41,739	0	0
Total Area	1,455 ft²	0 ft²	

*Average Load Procedure

Heating ΔT¹: 70.0

Est. Heating CFM²: 0

Heating Load Breakdown

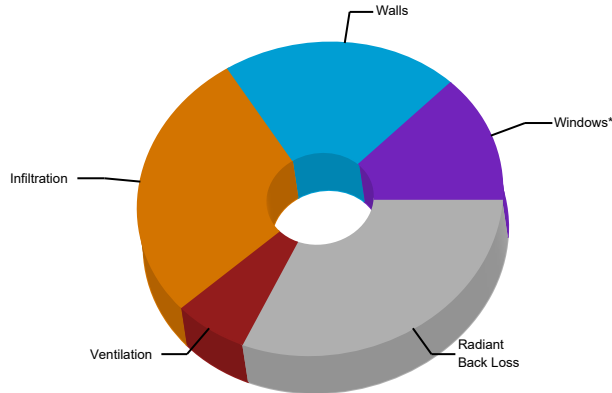

(1) ΔT: Difference between supply air and return air (2) Estimated air flow based on specified supply air ΔT

Length = ft Area = ft² Temperature = °F Flowrate = USGPM Air Flow = cfm Heat Loss = Btu/hr
Unit Heat Loss = Btu/(hr·ft²) Rv = hr·ft²·°F/btu Head Loss = ft water RH = Radiant Floor Heating
BB = Baseboard FA = Forced Air OTH = Other Heating SM = Snowmelt N = Not Heated

Created Using LoopCAD 2022 Uponor(US) (3/3/2026)
Software Version:22.0.0994 R (Trial)

Disclaimers

With the permission of the Air Conditioning Contractors of America ("ACCA"), material is reproduced from Manual J Residential Load Calculation (8th Edition) which is copyrighted by ACCA. The program and data are provided "as is" without warranty of any kind either expressed or implied. The entire risk as the quality and performance of the program and data is with you. In no event will ACCA be liable to you for any damages, including without limitation any lost profits, lost savings, or other incidental or consequential damages arising out of the use or inability to use this program or the data. © 2015 Air Conditioning Contractors of America. All Rights Reserved. www.acca.org

ACCA, Manual J and Powered by ACCA Manual J are registered trademarks of the Air Conditioning Contractors of America. All rights reserved.

Cold weather humidification, or some lifestyles that produce excessive moisture, may cause condensation to occur if the absolute humidity of the indoor air is too high for the momentary circumstances. Condensation can occur on surfaces or concealed within the structure, and can lead to mold, mildew, frost damage, and moisture damage. The software does not perform calculations for the estimation or detection of possible condensation problems, and it is the designers (i.e. software users) responsibility to do so independently if required. For guidance and additional cautions refer to ACCA Manual J 8th Edition, including Section 1-11 and Section 27.

The calculated values shown in this report are based on the data input by the user of the software. Inaccurate or erroneous data input will result in inaccurate or erroneous results. You are strongly advised to review all input data carefully, and to have the calculated results reviewed by an experienced heating professional to ensure reasonableness and suitability for your application.

IN NO EVENT WILL AVENIR SOFTWARE INC. ("AVENIR") OR ITS AFFILIATES BE LIABLE UNDER ANY CONTRACT, NEGLIGENCE, STRICT LIABILITY OR OTHER LEGAL OR EQUITABLE THEORY FOR ANY CONSEQUENTIAL, INCIDENTAL, INDIRECT OR SPECIAL OR PUNITIVE DAMAGES WHATSOEVER (INCLUDING, BUT NOT LIMITED TO, DAMAGES FOR LOSS OF BUSINESS PROFITS, BUSINESS INTERRUPTION, LOSS OF BUSINESS INFORMATION OR DATA AND THE LIKE), EVEN IF SUCH PARTY HAS BEEN ADVISED OF THE POSSIBILITY OF SUCH DAMAGES. AVENIR'S CUMULATIVE LIABILITY FROM ANY CAUSE RELATED TO OR ARISING FROM THE USE THIS REPORT, AND REGARDLESS OF THE FORM OF THE ACTION, SHALL BE LIMITED TO NO GREATER THAN THE AMOUNT OF FEES PAID TO AVENIR UNDER THE SOFTWARE LICENSE AGREEMENT.

(1) ΔT : Difference between supply air and return air (2) Estimated air flow based on specified supply air ΔT

Length = ft Area = ft² Temperature = °F Flowrate = USGPM Air Flow = cfm Heat Loss = Btu/hr
 Unit Heat Loss = Btu/(hr·ft²) Rv = hr·ft²·°F/btu Head Loss = ft water RH = Radiant Floor Heating
 BB = Baseboard FA = Forced Air OTH = Other Heating SM = Snowmelt N = Not Heated

Created Using LoopCAD 2022 Uponor(US) (3/3/2026)
 Software Version:22.0.0994 R (Trial)

